

## MICRO SWITCH Force Sensors

### Force Sensor

### *FS Series*

#### FEATURES

- Robust performance characteristics
- Precision force sensing
- Adaptable product design
- Highly reliable
- Signal conditioning available
- Electrically ratiometric output
- Extremely low deflection (30 microns typical @ Full Scale)
- Low repeatability errors ( $\pm 0.2\%$  Span)
- Low linearity errors ( $\pm 0.5\%$  Span)
- Low off-center loading errors
- Resolution to 1.0 gram force
- Fast response time
- Low power consumption
- High ESD resistance - 10 KV

#### TYPICAL APPLICATIONS

- Medical infusion pumps
- Kidney dialysis machines
- Robotic end-effectors
- Variable tension control
- Load and compression sensing
- Contact sensing



The FS Series Force Sensor provides precise, reliable force sensing performance in a compact commercial grade package. The sensor features a proven sensing technology that utilizes a specialized piezoresistive micro-machined silicon sensing element. The low power, unamplified, non-compensated Wheatstone bridge circuit design provides inherently stable mV outputs over the 1,500 gram force range.

The force sensor operates on the principle that the resistance of silicon implanted piezoresistors will increase when the resistors flex under an applied force. The sensor concentrates force from the application through the stainless steel plunger directly to the silicon sensing element. The amount of resistance changes in proportion to the amount of force being applied. This change in circuit resistance results in a corresponding mV output level.

The sensor package design incorporates a patented modular construction. The use of innovative elastomeric technology and engineered molded plastics results in load capacities of 5.5 Kg over-force. The stainless steel plunger provides excellent mechanical stability and is adaptable to a variety of applications. Various electrical interconnects can accept pre-wired connectors, printed circuit board mounting, and surface mounting. The unique sensor design also provides a variety of mounting options including mounting brackets, as well as application-specific mounting requirements.

# MICRO SWITCH Force Sensors

## Force Sensor

FS Series

### PERFORMANCE CHARACTERISTICS @ $10 \pm 0.01$ VDC, 25°C

Preliminary, based on limited test data

Parameter	Min.	Typ.	Max.	Units
Excitation*	—	10	12	VDC
Null shift, 25 to 0°, 25 to 50°C	—	$\pm 0.5$	—	mV
Null offset	-30	0	+30	mV
Linearity (BFSL)	—	$\pm 0.5$	—	% Span
Sensitivity	—	0.24	—	mV/grf
Sensitivity shift 25 to 0°, 25 to 50°C	—	$\pm 5.0$	—	% Span
Repeatability	—	$\pm 0.2$	—	% Span
Response time	—	—	1.0	msec
Input resistance	—	5.0 K	—	ohms
Output resistance	—	5.0 K	—	ohms
Plunger deflection	—	30	—	microns
Weight	—	2.0	—	grams
ESD (direct contact - terminals and plunger)	10	—	—	kVolts

\* Non-compensated force sensors, excited by constant current (1.5 mA) instead of voltage, exhibit partial temperature compensation of Span.

### ENVIRONMENTAL SPECIFICATIONS

Operating temperature	-40 to +85°C (-40 to +185°F)
Storage temperature	-55 to +105°C (-67 to +221°F)
Shock	Qualification tested to 150 g
Vibration	Qualification tested to 0 to 2 kHz, 20 g sine

**Note:** All force related specifications are established using dead weight or compliant force.

### ORDER GUIDE

Catalog Listing	Force Range (grams)	Span, mV			Overforce grams Max.
		Min.	Typ.	Max.	
FSG-15N1A	1,500	290	360	430	5,500

### MOUNTING

The sensor output characteristics do not change with respect to mounting orientation. Care should be taken not to obstruct the vent hole in the bottom of the sensor housing. Improper venting may result in unstable output.

Mounting bracket mounting torque: 2-5 in. lb. (.21-.56 Nm).

### APPLYING FORCE

Evaluation of the sensor is to be performed using dead-weight or compliant force. Application of a rigid, immobile force will result in output drift (decrease) as elastomeric seals relax. Off-center plunger loading has minimal effect on sensor performance and maintains operation within design specifications.

### EXCITATION SCHEMATIC

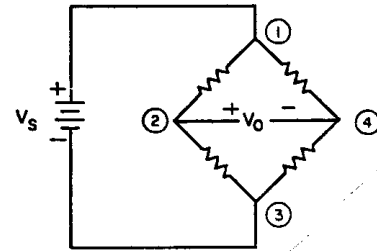

### FS SERIES CIRCUIT

1. Circled numbers refer to sensor terminals (pins). Pin 1 is designated with a notch. Pin 1 = Supply  $V_s$  (+) Pin 2 = Output, (+) Pin 3 = Ground, (-) Pin 4 = Output, (-)
2. The force sensor may be powered by voltage or current. Maximum supply voltage is not to exceed 12 volts. Maximum supply current is not to exceed 1.6 mA. Power is applied across Pin 1 and Pin 3.
3. The sensor output should be measured as a differential voltage across Pin 2 and Pin 4 ( $V_o = V_2 - V_4$ ). The output is ratiometric to the supply voltage. Shifts in supply voltage will cause shifts in output. Neither Pin 2 nor Pin 4 should be tied to ground or voltage supply.

# MICRO SWITCH Force Sensors

Force Sensor

*FS Series*

## MOUNTING DIMENSIONS (for reference only)

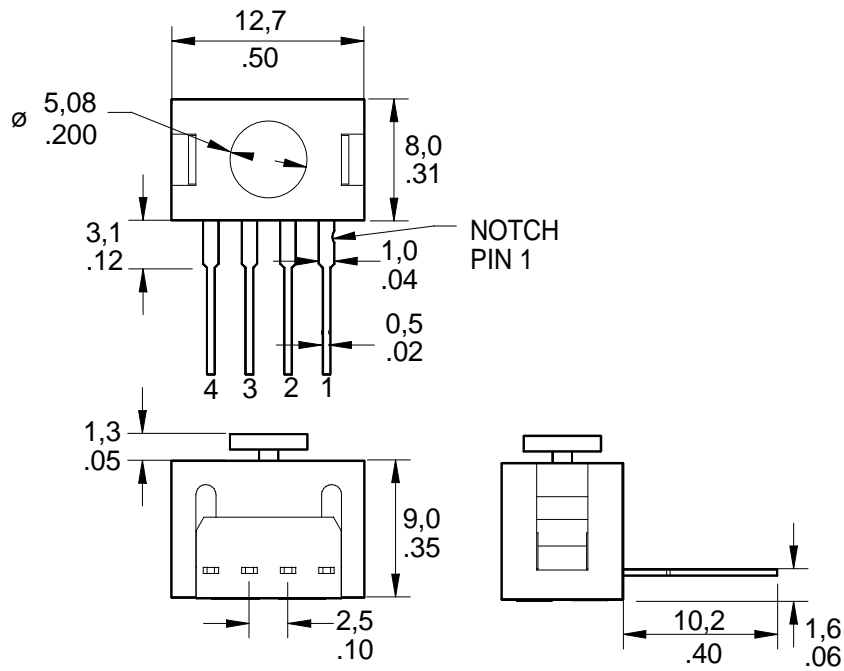

## ACCESSORY

Catalog Listing	Description
PC15132	Plastic mounting bracket

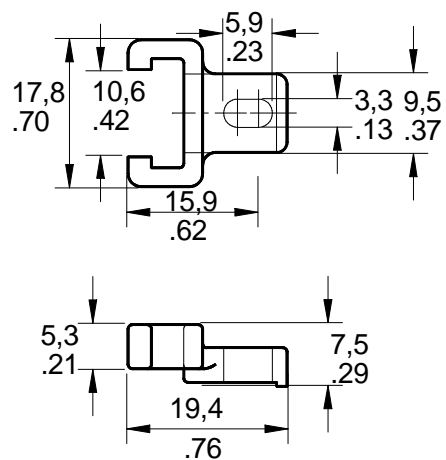

# MICRO SWITCH Force Sensors

Force Sensor

*FS Series*

## **SALES AND SERVICE**

Honeywell's MICRO SWITCH Division serves its customers through a worldwide network of sales offices and distributors. For application assistance, current specifications, pricing or name of the nearest Authorized Distributor, contact a nearby sales office. Or call:

1-800-537-6945 USA  
1-416-293-8111 Canada  
1-815-235-6847 International

## **INTERNET**

<http://www.sensing.honeywell.com>  
[info@micro.honeywell.com](mailto:info@micro.honeywell.com)

Specifications may change without notice. The information we supply is believed to be accurate and reliable as of this printing. However, we assume no responsibility for its use.

While we provide application assistance, personally and through our literature, it is up to the customer to determine the suitability of the product in the application.

---

# **Honeywell**

**Sensing & Control**  
Honeywell Inc.  
11 West Spring Street  
Freeport, Illinois 61032



Printed with Soy Ink  
on 50% Recycled Paper

84-08028-0 796 Printed in USA

*Helping You Control Your World*