

## DV 6248 / 2A - 00201

Mixed flow fan with electronically commutated external rotor DC drive. Drive electronics is completely integrated into the fan hub. The aluminium die-cast housing and plastic impeller are aerodynamically dimensioned for optimum air flow characteristics at minimum noise. The air flow and noise level can be controlled by varying the supply voltage.

Features:

- Electronic motor current limiting during start-up or blocking. Continuous blocking protection. Electronically safeguarded against incorrect polarity.
- Extremely low EMI.



### General Data

Nominal voltage	V DC	48
Voltage range	V DC	36 ... 72
Nominal Speed	min <sup>-1</sup>	4300
Max. flow rate	m <sup>3</sup> /h	540
Max. flow rate	CFM	317.6
Noise free air	dB(A)	63
Noise in opt. operating range	bels	6.9
Current consumption	mA	880
Power consumption max	W	42
Perm. ambient temperature at max. voltage	°C	-20 ... +75
Service life at 75 °C	h	40,000
Service life at 40 °C	h	90,000
Fan housing / impeller		metal / PA 6.6
Bearing system		Ball bearings
Mass	kg	0.82

All data are average figures at nominal voltage.

Subject to technical change.

### Tacho-Signal

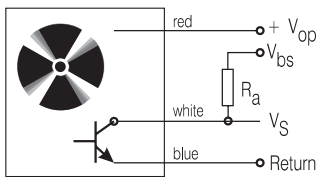

Output	2 pulses/revolution
V <sub>S</sub> high at I <sub>source</sub> = 0 mA	24 V
V <sub>S</sub> low at I <sub>sink</sub> = 2 mA	≤ 0.4 V
V <sub>bs</sub>	24 VDC
I <sub>sink</sub>	≤ 20 mA

$$R_a = \frac{V_{bs} - V_{s \text{ Low}}}{I_{\text{sink}}}$$

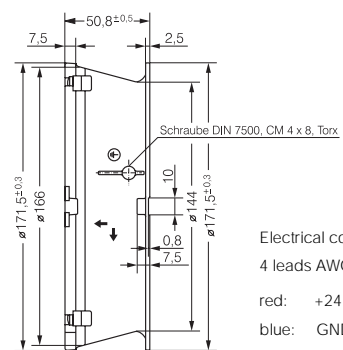
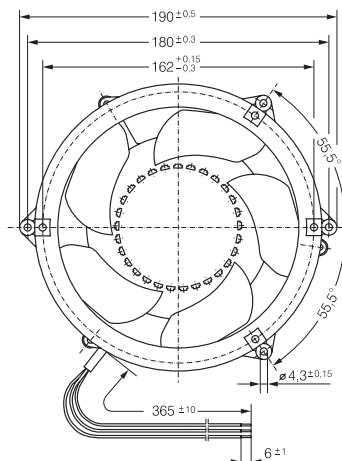
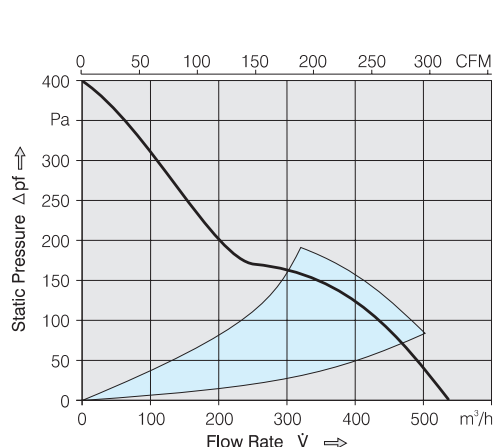

Electrical connection via  
4 leads AWG 28, TR 64

- red: +24 VDC
- blue: GND 0 V
- white: Tachometer output
- violet: Speed control input

### Commutation circuit

Nominal Voltage:	$V_N = 48 \text{ V DC}$
Voltage range:	$V = (36 \dots 72) \text{ V DC}$
Current consumption:	$I_N (\text{Speed Control Input} \geq 9,5 \text{ V}) \sim 875 \text{ mA}$ $I_N (\text{Speed Control Input} = 5 \text{ V}) \sim 130 \text{ mA}$ $I_N (\text{Speed Control Input} \leq 0,5 \text{ V}) \sim 20 \text{ mA}$
Speed:	$n_N (\text{Speed Control Input} \geq 9,5 \text{ V}) \sim 4300 \text{ rpm}$ $n_N (\text{Speed Control Input} = 5 \text{ V}) \sim 1880 \text{ rpm}$ $n_N (\text{Speed Control Input} \leq 0,5 \text{ V}) \sim 0 \text{ rpm}$
Temperature range:	$\vartheta_{\text{amb}} = -20 \dots +75 \text{ }^\circ\text{C}$

### Speed control input specification ( A )

Speed Control-Signal:	Low ( $\leq 0,5\text{V}$ )	$n = 0 \text{ rpm}$
	High ( $\geq 9,5\text{V}$ )	HighSpeed

